

40W DC/DC Switching Power Supply

HF40W-SD Series



FEATURES

- Full DC input range
- High reliability
- Japanese brand components for key parts
- Electrolytic capacitors all 105°C
- 100% full load burn-in test
- Protections: overload/ short circuit
- 5 years limited warranty
- F603 129 x 98 x 40mm

SPECIFICATIONS

DC Input Voltage	24V(18~36), 48V(36~72) 110V(72~144)VDC
Line Regulation (full load)	± 0.5%
Voltage Adjust Range	± 10%
Output Overload Protection	105~150%, hiccup mode, auto recovery
Short Circuit Protection	hiccup mode, auto recovery
Rise Time	50ms @full load (typical)
Mechanical Feature	enclosed
Dimensions	129 x 98 x 40mm (L x W x H)
Operating Temperature	-20°C ~+50°C
Storage Temperature	-20°C ~+85°C
Operating Humidity	20%~93%RH(non condensing)
Storage Humidity	20%~95%RH(non condensing)

MTBF	>100,000 hours
Cooling	convection
Safety Standards	design refer to GB4943, UL60950, EN60950
EMC Standards	design refer to GB9254, EN55022 Class A, EN61000
Withstand Voltage	I/P -O/P: 1.5KVAC/1min I/P - PE: 1.5KVAC/1min O/P-PE: 0.5KVAC/1min
Isolation Resistance	>100MΩ@500VDC
Vibration	10~150Hz, 2G 10min/1cycle, 30min each along X, Y, Z axes
Connection	5P/9.5mm screw terminal block
Packing	0.34kgs, 42pcs/16.5kgs/0.035CBM per carton

Model No.	DC Output	Rated Power	Load Regulation	Voltage Tolerance	Ripple & Noise (max.)	Efficiency
HF40W-SD24-5	5V 8.0A	40.0W	0.5%	± 2%	80mVp-p	75%
HF40W-SD48-5	5V 8.0A	40.0W	0.5%	± 2%	80mVp-p	77%
HF40W-SD110-5	5V 8.0A	40.0W	0.5%	± 2%	80mVp-p	77%
HF40W-SD24-12	12V 3.3A	39.6W	0.5%	± 1%	120mVp-p	79%
HF40W-SD48-12	12V 3.3A	39.6W	0.5%	± 1%	120mVp-p	81%
HF40W-SD110-12	12V 3.3A	39.6W	0.5%	± 1%	120mVp-p	81%
HF40W-SD24-24	24V 1.6A	38.4W	0.5%	± 1%	150mVp-p	84%
HF40W-SD48-24	24V 1.6A	38.4W	0.5%	± 1%	150mVp-p	85%
HF40W-SD110-24	24V 1.6A	38.4W	0.5%	± 1%	150mVp-p	85%
HF40W-SD24-48	48V 0.8A	38.4W	0.5%	± 1%	150mVp-p	84%
HF40W-SD48-48	48V 0.8A	38.4W	0.5%	± 1%	150mVp-p	85%
HF40W-SD110-48	48V 0.8A	38.4W	0.5%	± 1%	150mVp-p	86%

NOTE

1. All parameters are measured at rated input voltage, rated load and 25°C of ambient temperature.
2. Line regulation is measured from low line to high line at rated load.
3. Load regulation is measured from 0% to 100% of rated load for single output models. For multi-output models, it is measured from 20% to 100% of rated load, and other output at 60% rated load.
4. Ripple & noise are measured at 20MHz of bandwidth by using a 12" twisted pair-wire terminated with a 0.1uF & 47uF parallel capacitor.
5. The power supply is regarded as a component which will be installed into a final equipment. The final equipment must be re-confirmed that it still meets EMC directives.

Drawing

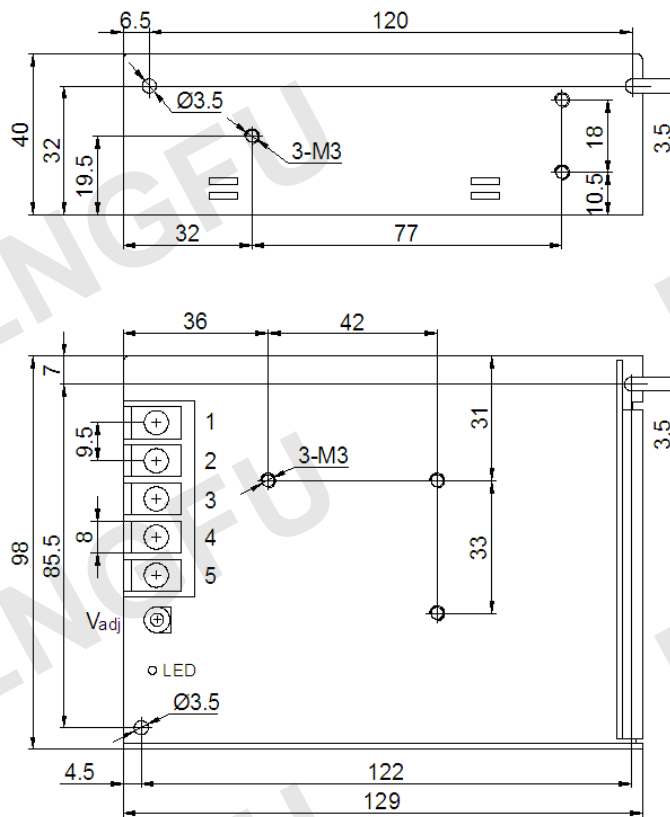

Terminal Pin No. Assignment

Pin No.	Assignment	Pin No.	Assignment
1	DC INPUT -V	4	DC OUTPUT -V
2	DC INPUT +V	5	DC OUTPUT +V
3	PE		