

## 60W Single Output Switching Power Supply

HF60W-SL Series



### FEATURES

- Universal AC input / full range
- Japanese brand components for key parts
- Electrolytic capacitors all 105°C
- 100% full load burn-in test
- Approvals: UL, CE
- Protections: overload/ over voltage/ short circuit
- 5 years limited warranty
- F605 160 x 98 x 39mm

### SPECIFICATIONS

Input Voltage	85~264VAC (120~370VDC)
Input Current	2.0A
Input Frequency	47~63Hz
Inrush Current	cold start, 20A/115V, 40A/230V
Input Leakage Current	< 1mA/230VAC
Line Regulation (full load)	± 0.5%
Voltage Adjust Range	± 10%
Output Overload Protection	105~150%, hiccup mode, auto recovery
Output Over Voltage Protection	115~150%, hiccup mode, auto recovery
Short Circuit Protection	hiccup mode, auto recovery
Rise Time	50ms @full load (typical)
Hold up Time	20ms @full load (typical)
Mechanical Feature	enclosed
Dimensions	160 x 98 x 39mm (L x W x H)

Operating Temperature	-20°C ~+70°C(ref. derating curve)
Storage Temperature	-20°C ~+85°C
Operating Humidity	20%~93%RH(non condensing)
Storage Humidity	20%~95%RH(non condensing)
MTBF	>100,000 hours
Cooling	convection
Safety Standards	GB4943, UL60950, EN60950
EMC Standards	GB9254, EN55022 Class B EN55024, EN61000-3-2,3 EN61000-4-2,3,4,5,6,8,11
Withstand Voltage	I/P -O/P: 3.0KVAC/1min I/P - PE: 1.5KVAC/1min O/P-PE: 0.5KVAC/1min
Vibration	10~150Hz, 2G 10min/1cycle, 30min each along X, Y, Z axes
Connection	5P/9.5mm screw terminal block
Packing	0.46kgs, 30pcs/15.5kgs/0.031CBM per carton

Model No.	DC Output	Rated Power	Load Regulation	Voltage Tolerance	Ripple & Noise (max.)	Efficiency
HF60W-SL-5	5V 12A	60.0W	0.5%	± 2%	80mVp-p	78%
HF60W-SL-12	12V 5.0A	60.0W	0.5%	± 1%	120mVp-p	82%
HF60W-SL-15	15V 4.0A	60.0W	0.5%	± 1%	120mVp-p	82%
HF60W-SL-24	24V 2.5A	60.0W	0.5%	± 1%	150mVp-p	81%
HF60W-SL-48	48V 1.3A	62.4W	0.5%	± 1%	150mVp-p	82%

\* 3~48VDC output all available

### NOTE

1. All parameters are measured at 230VAC input, rated load and 25°C ambient temperature.
2. Line regulation is measured from low line to high line at rated load.
3. Load regulation is measured from 0% to 100% of rated load for single output models. For multi-output models, it is measured from 20% to 100% of rated load, and other output at 60% rated load.
4. Ripple & noise are measured at 20MHz of bandwidth by using a 12" twisted pair-wire terminated with a 0.1uF & 47uF parallel capacitor.
5. The power supply is regarded as a component which will be installed into the final equipment. The final equipment must be re-confirmed that it still meets EMC directives.

### Drawing

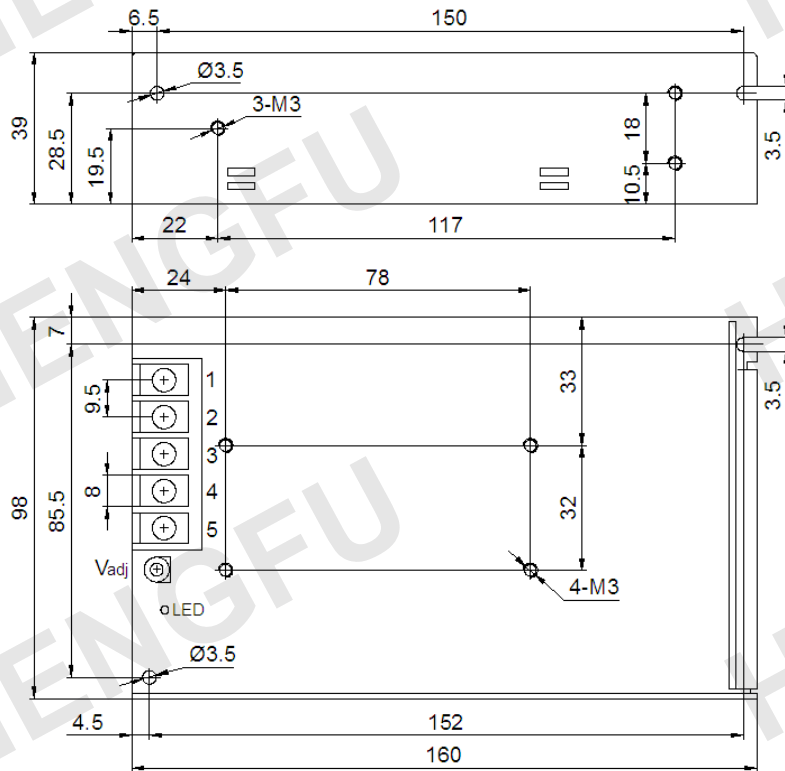

Terminal Pin No. Assignment

Pin No.	Assignment	Pin No.	Assignment
1	AC/L	4	DC OUTPUT -V
2	AC/N	5	DC OUTPUT +V
3	PE		

### Block Diagram

